

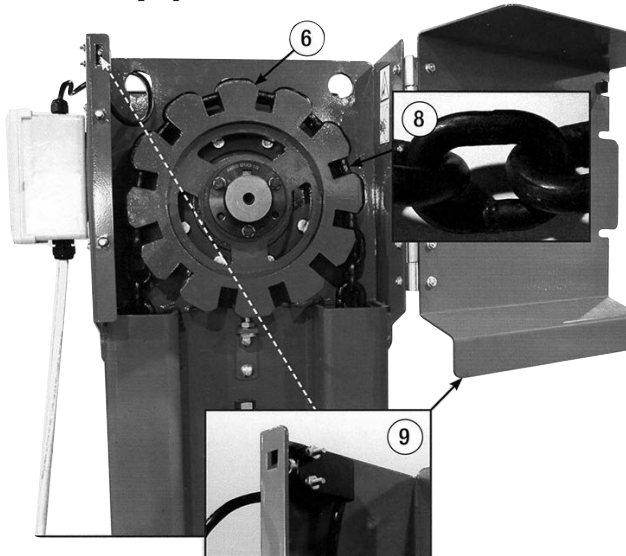

**The IntelliChain® Alley Scraper System
has the brawn and the brains needed
to keep your herd clean 24/7/365!**



- ⑥ **Pocket sprocket** cradles the chain, effectively driving it in forward or reverse. Connected to the reducer with a tapered bushing, the pocket sprocket is easy to replace (sprockets available in four different colored stages for easy identification)
- ⑧ **Patz chain** is made of high-quality 1/2" (13mm) hardened steel to withstand the stress and friction of contact between links and concrete alleys. To ensure you always receive genuine Patz chain, every sixth link is imprinted with 'PTZ'. Patz chain can be ordered in a variety of lengths, including custom lengths in one-foot increments for splice-free installation.
- ⑨ **Guard doors** provide safety for operators and protection for drive unit components. Opening a guard door will activate a **safety interlock** that automatically shuts the unit down.



Designed with your operation in mind!

- Advanced SmartSense® learning system constantly adjusts to weather, bedding, and manure changes while recalculating the amount of energy required to clean
- Energy-efficient planetary gearbox powered by single 3/4 hp motor
- Narrow, space-saving drive unit design provides ultimate layout flexibility
- Slider sleds available for layouts with alleys of unequal length
- Total circuit up to 1,000 ft. (305m)
- On-floor or recessed chain installation available — easily installs in new or existing barns!
- Low maintenance user-friendly system!

Wylie Implement

14541 Barber Creek, Kent City, MI
(616) 678-7615 • Fax (616) 678-7686
Toll Free: 1-888-515-5050